

Technical Note

Date: 10/21/08
 Product(s): 1756sc-IF8H, 1756sc-OF8H, 1756sc-IF8u, 1756sc-CTR8
 Product Revision: NA
 Information: AIFM options
 Document # TN102108-01

The selection table below (*Table 1*) lists available Allen-Bradley pre-wired cables and AIFM modules that best fit our Spectrum 1756 analog modules. For details on the Allen-Bradley 1492 pre-wired systems, please refer to the AB publication titled "Digital/Analog Programmable Controller Wiring Systems", (Publication 1492-TD008C-EN-P).

Table 1

1756sc-IF8H	8-channel analog input module with HART protocol	1492-AIFM8-3 ¹	1492-ACABLE-UC (Diff Voltage) or 1492-ACABLE-UD (Diff. Current)
1756sc-OF8H	8-channel analog output module with HART protocol	1492-AIFM8-3	1492-ACABLE-WA (Voltage) or 1492-ACABLE-WB (Current)
1756sc-IF8u	Universal 8-channel analog input module	1492-IFM-40F	1492-ACABLE--XXXsc ²
1756sc-CTR8	8-channel high speed counter module	Not Available	Not Available

¹ You may substitute one of three fused AIFM blocks (i.e. 1492-AIFM8-F-5, 1492-AIFM16-F-3, 1492-AIFM16-F-5)

² Where XXX is the length (010, 020, 030, 050, 070) 1, 2, 3, 5 or 7 meter lengths respectively.

The figures below describe the correct wiring for the Spectrum analog modules.

Figure 1

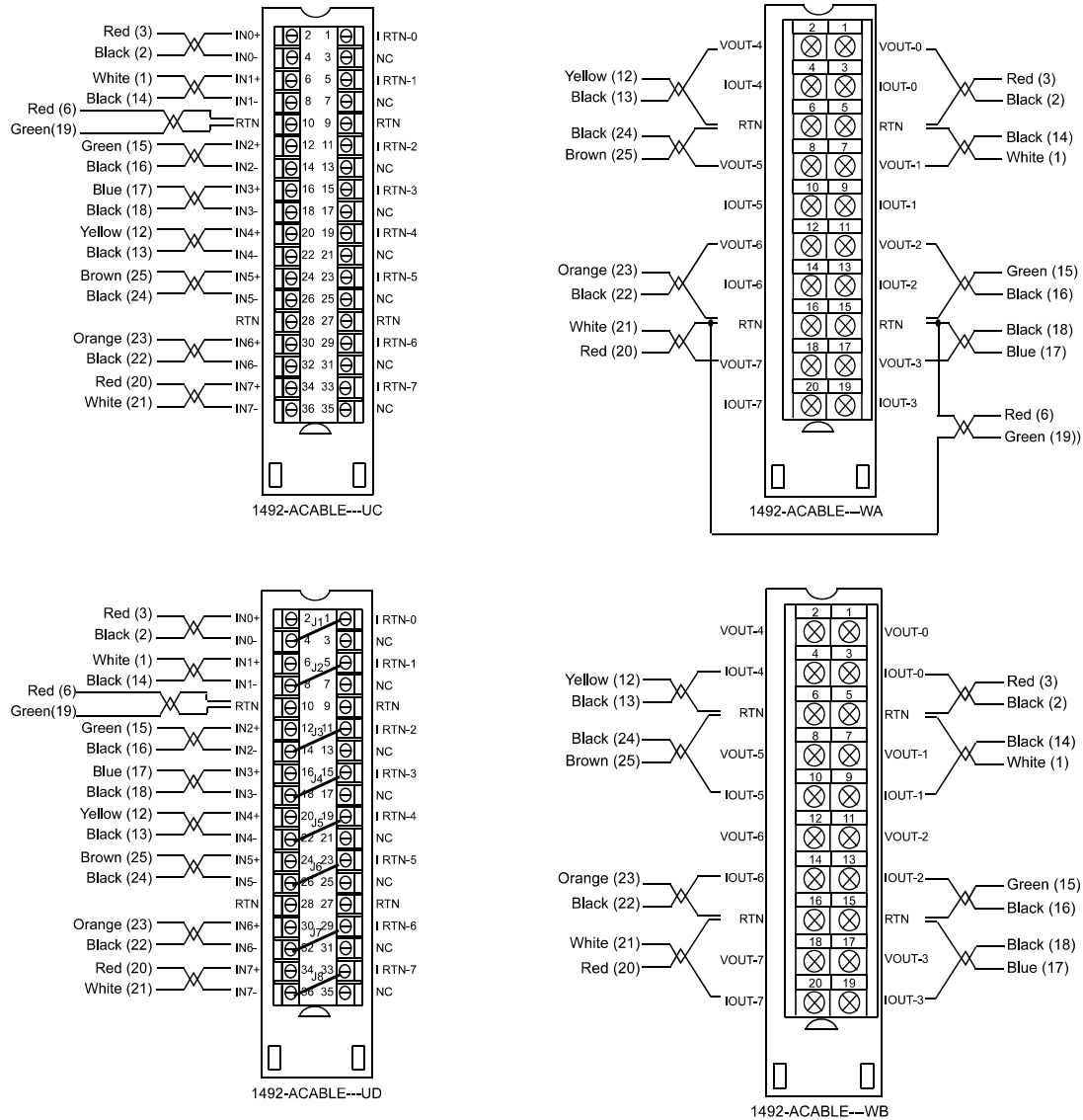

Note: The numbers listed above in parenthesis refer to the ACABLE pin number. Use these numbers to determine the appropriate AIFM terminal numbers in figures 7 and 8.

Note: The IF8H and OF8H use the same cable and IFM module as the Allen-Bradley IF16 and OF8 respectively.

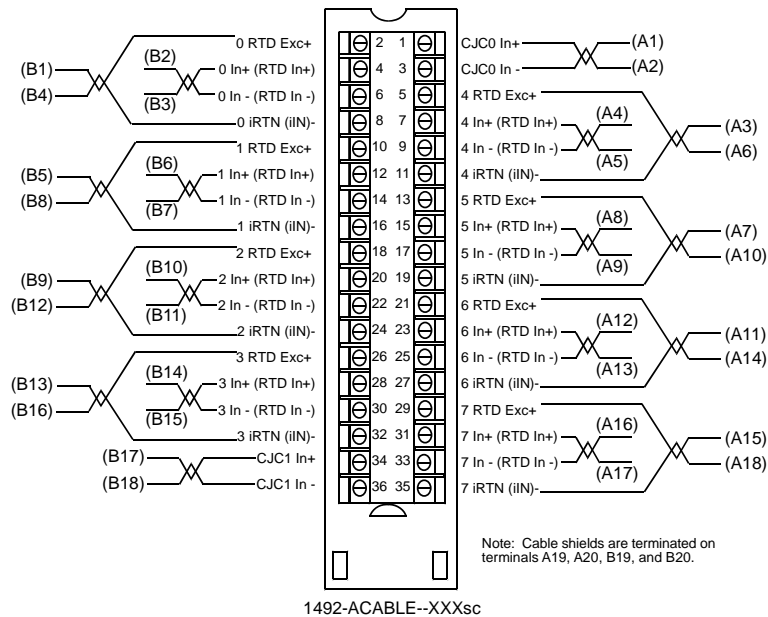

The layout for the Allen-Bradley IFM blocks are shown in figures 2 and 6.

Figure 2 (1492-AIFM8-3)

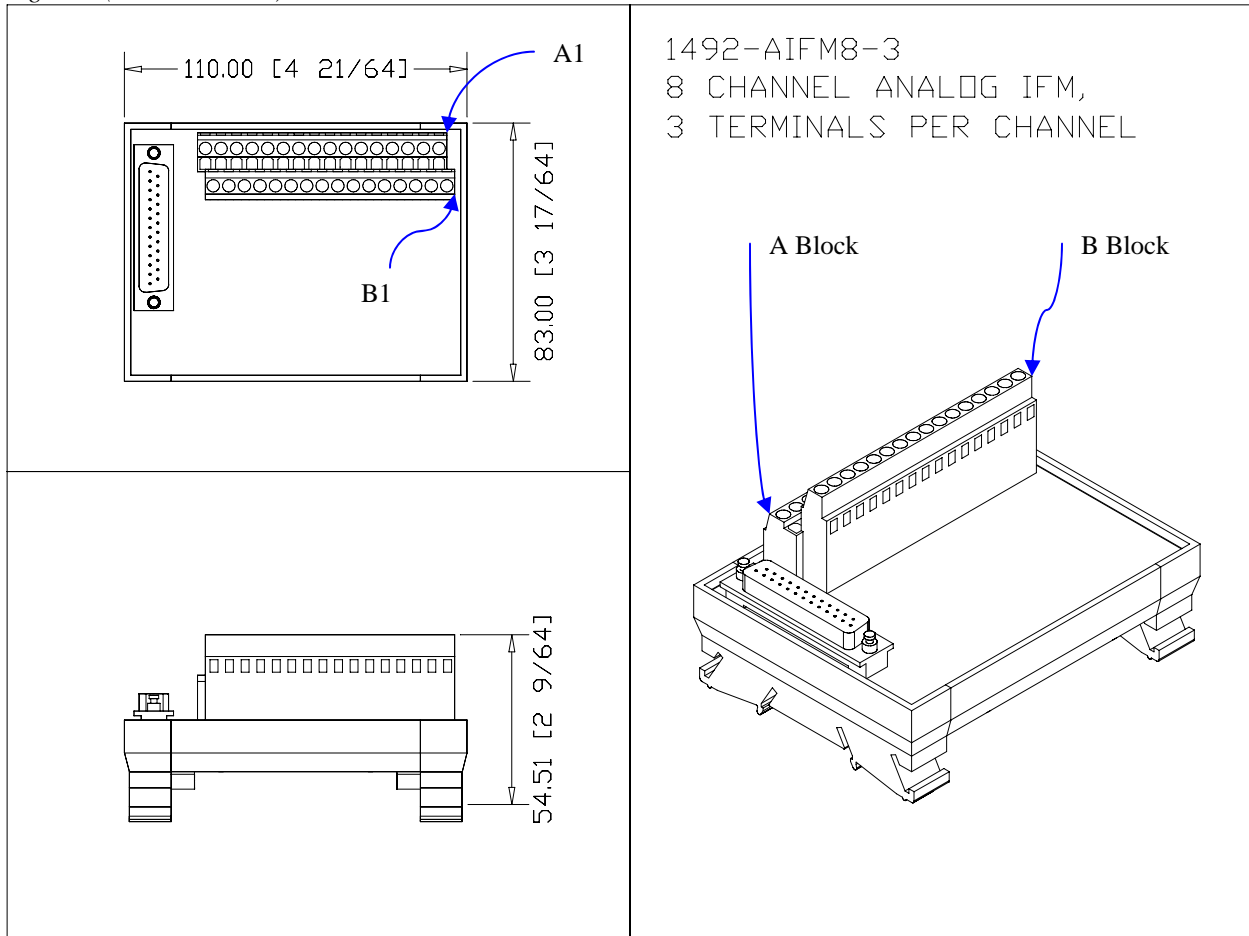

Figure 3 (1492-IFM40F)

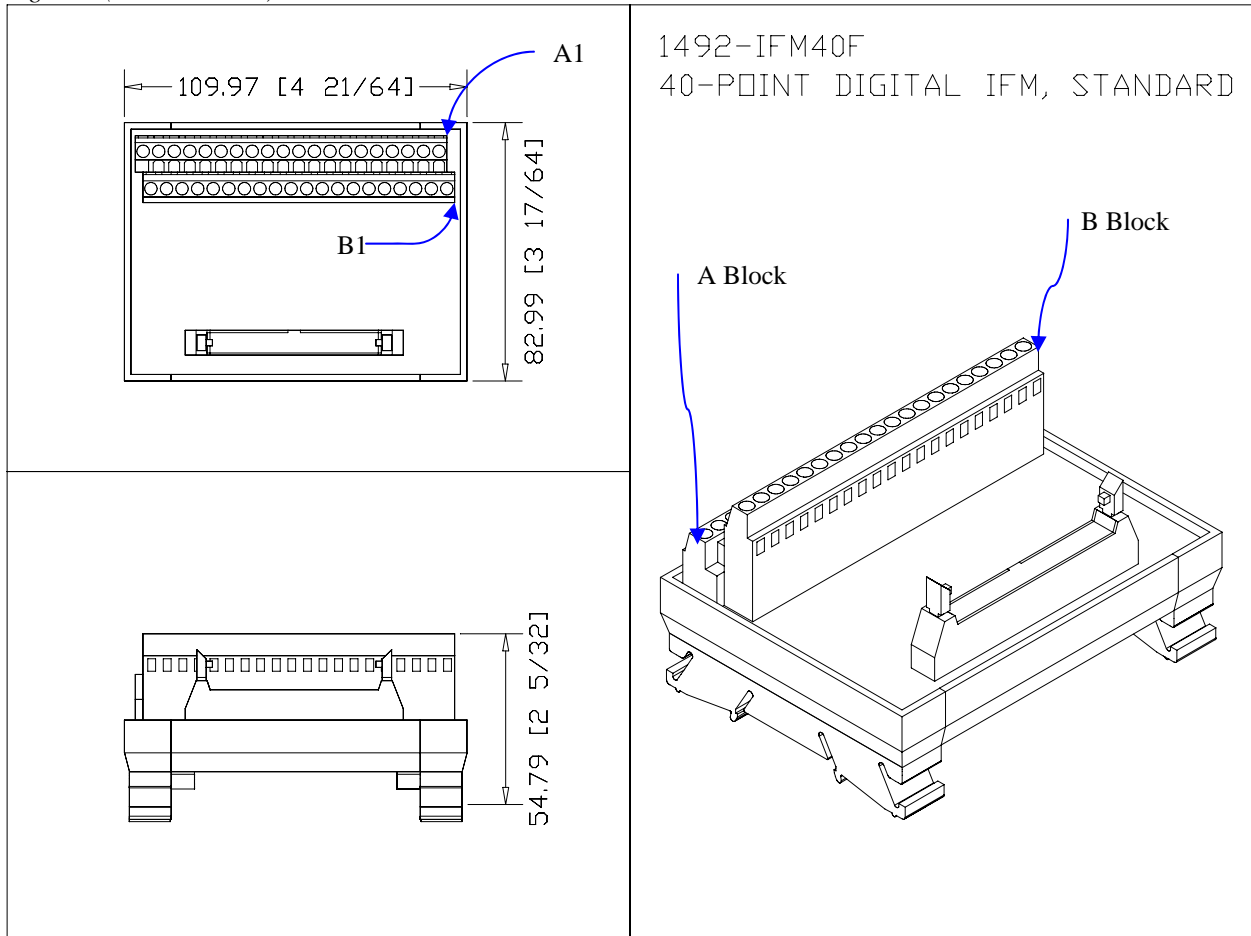

Figure 4 (1492-AIFM8-F-5)

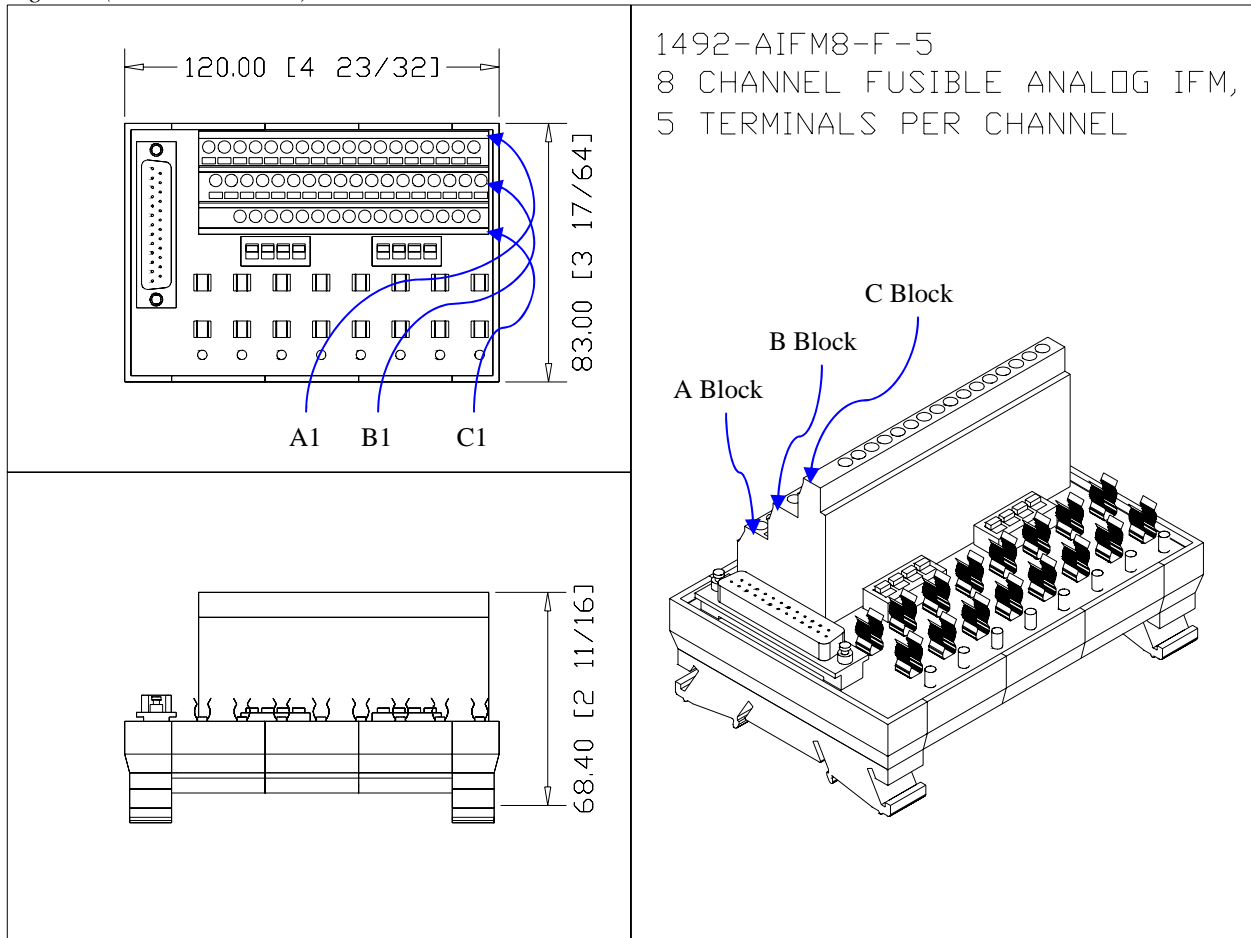

Figure 5 (1492-AIFM16-F-3)

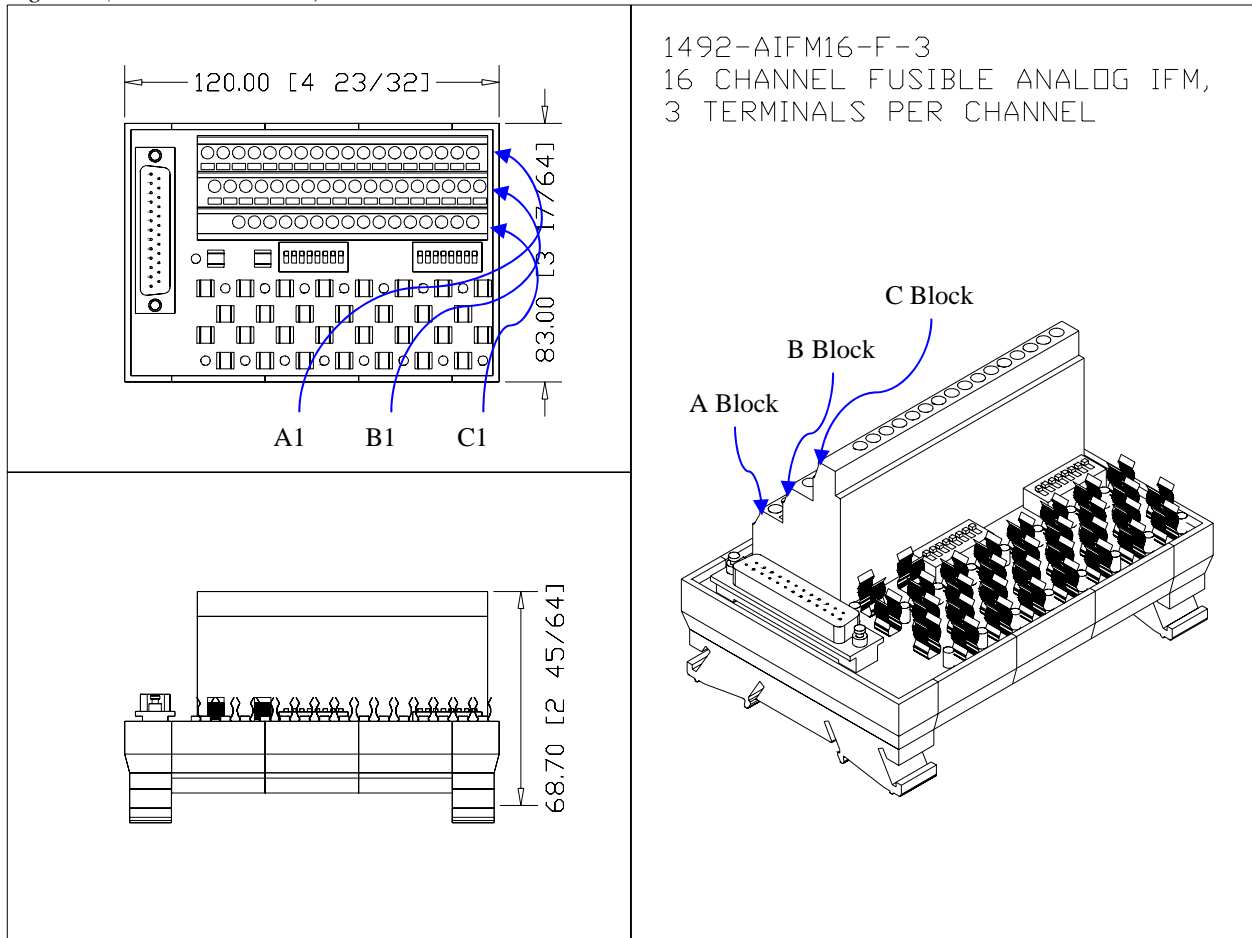

Figure 6 (1492-AIFM-16_F-5)

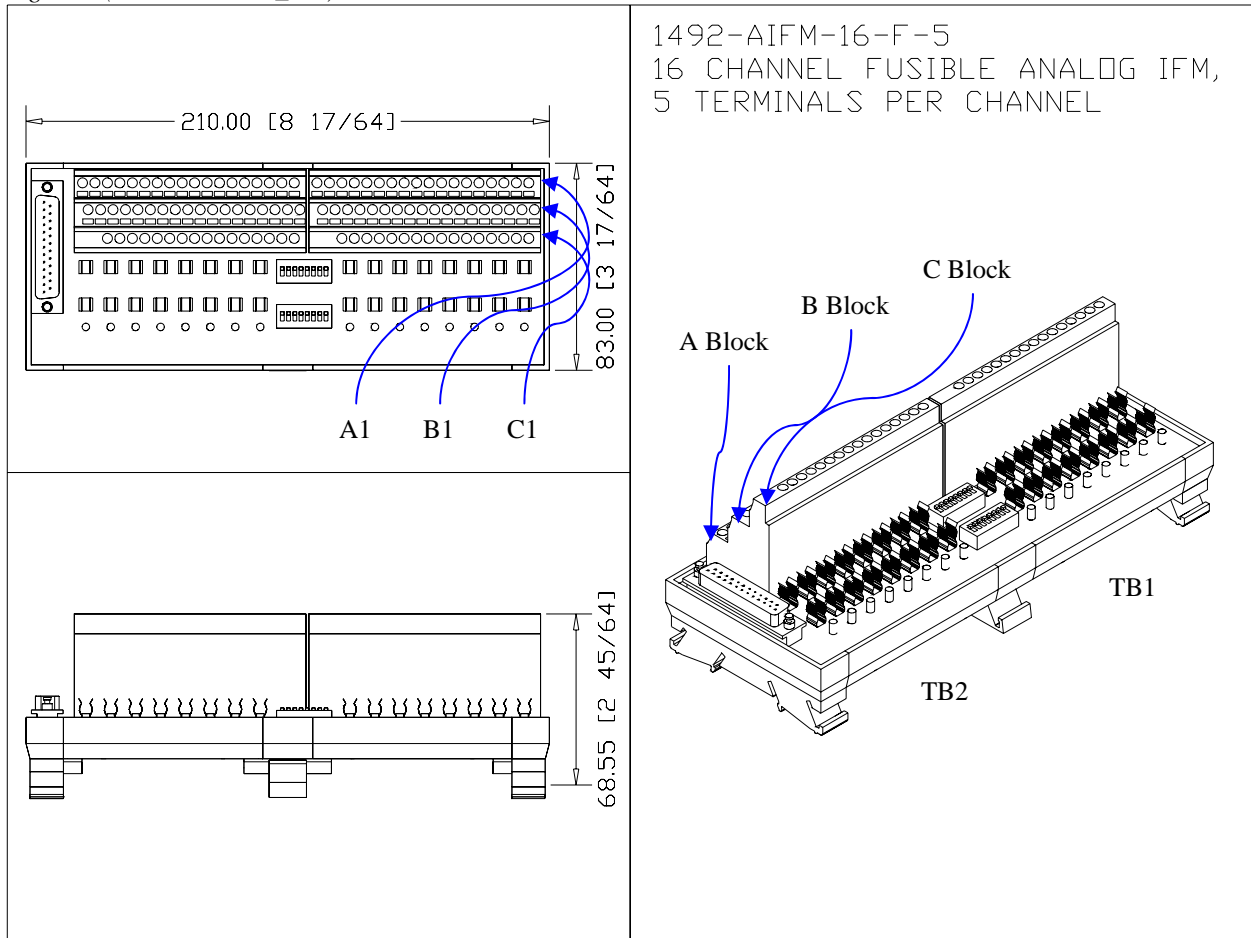

Figure 7 (AIFM Pinouts)

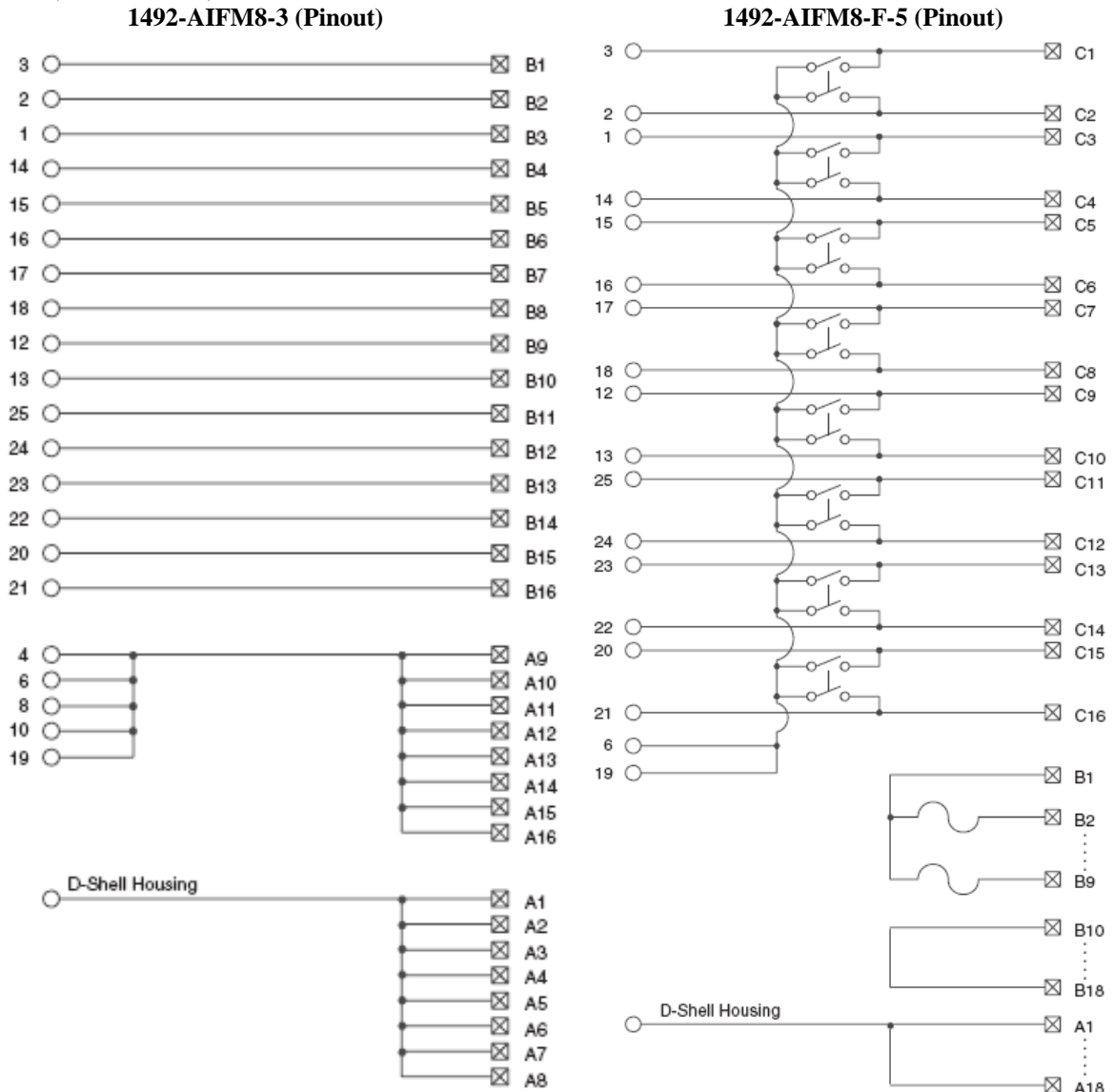
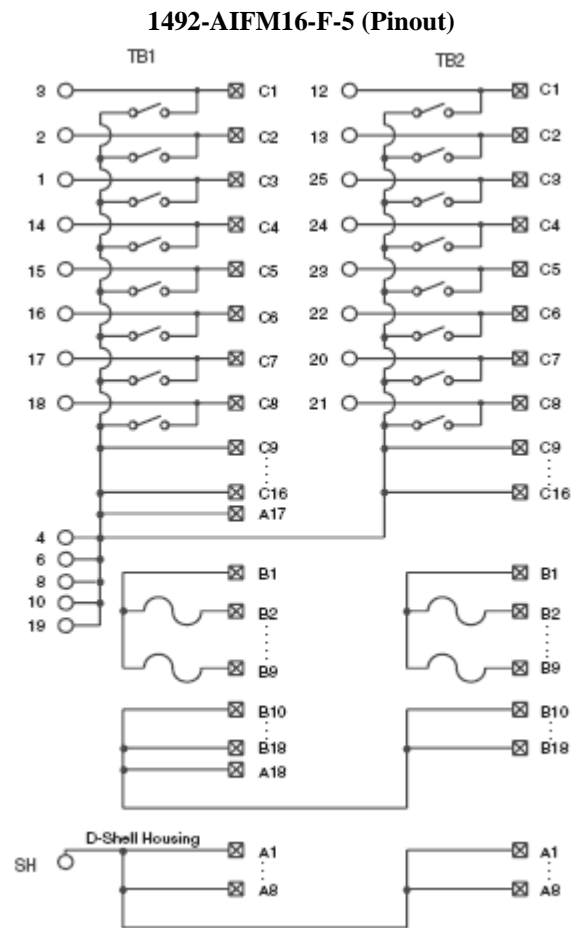
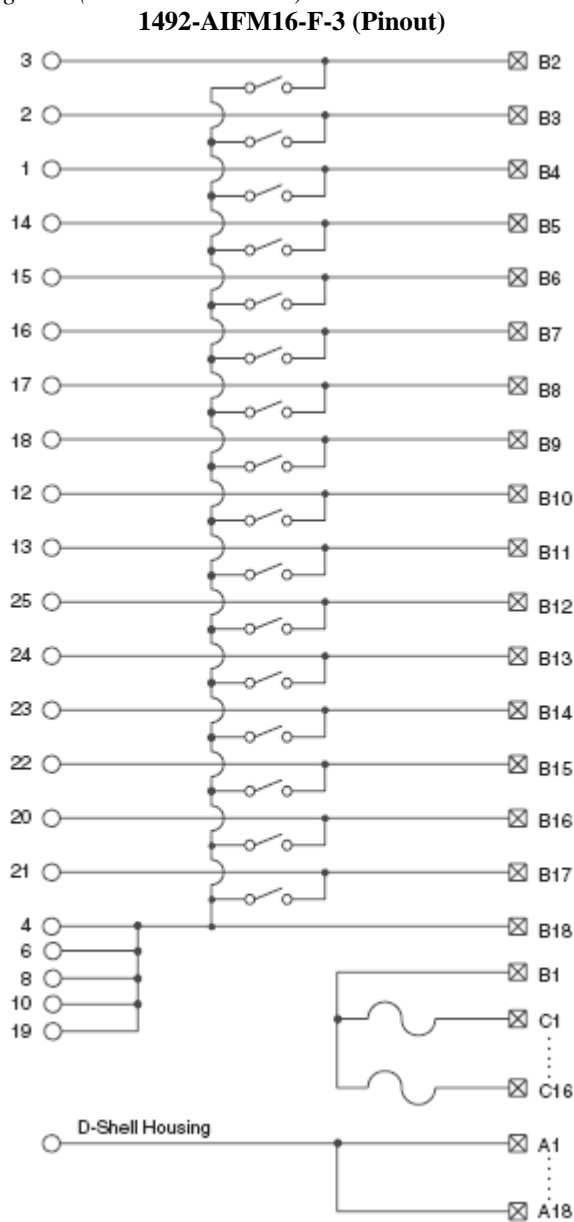
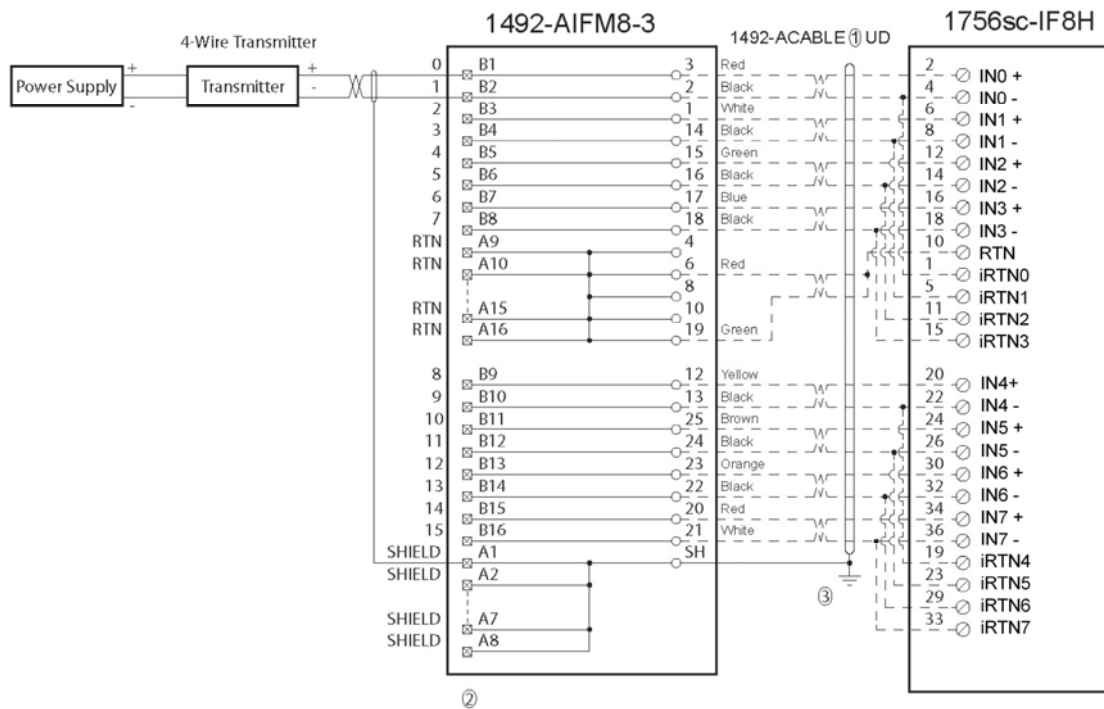

Figure 8 (AIFM Pinout Cont.)



1756sc-IF8H (8 Differential Current) with 1492-AIFM8-3



① Cables are available in 0.5m, 1.0m, 2.5m, and 5.0m standard lengths (005=0.5m, 010=1.0m, 025=2.5m, 050=5.0m). Custom length cables are also available.

② Terminals starting with A are the lower row of terminals, B terminals are the upper row.

③ Follow your PLC Analog User Manual for proper shield grounding instructions.

1756sc-IF8H (8 Differential Voltage) with 1492-AIFM8-3

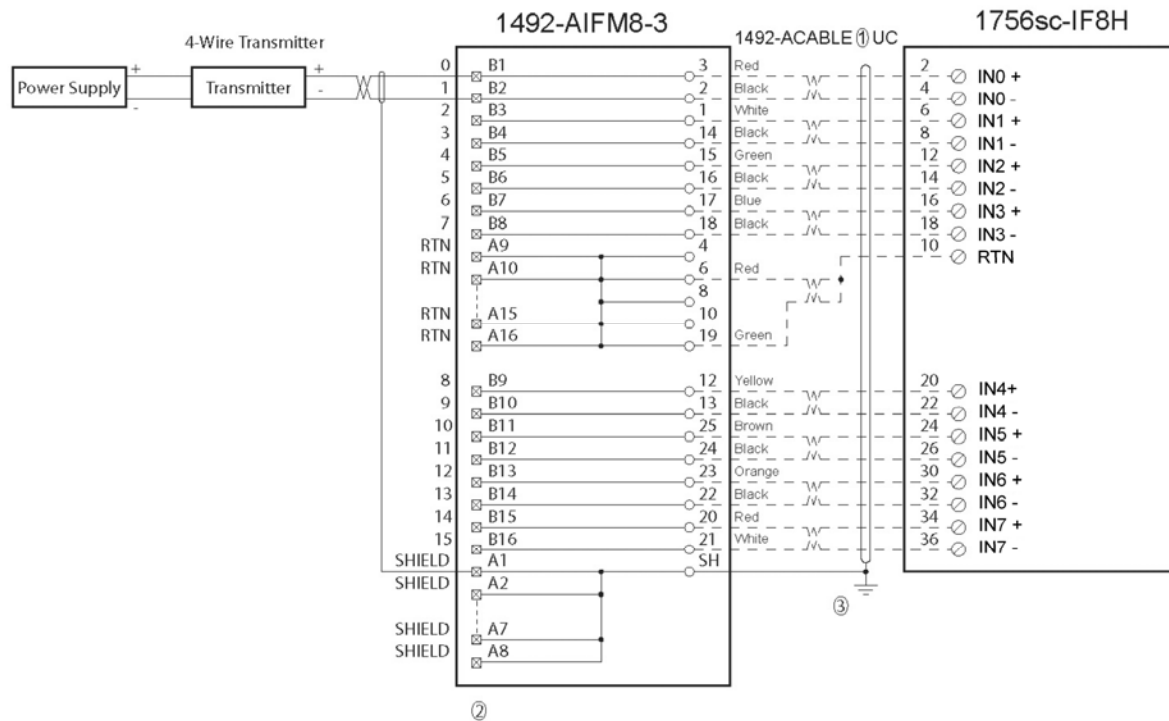

① Cables are available in 0.5m, 1.0m, 2.5m, and 5.0m standard lengths (005=0.5m, 010=1.0m, 025=2.5m, 050=5.0m). Custom length cables are also available.

② Terminals starting with A are the lower row of terminals, B terminals are the upper row.

③ Follow your PLC Analog User Manual for proper shield grounding instructions.

1756sc-IF8H (8 Differential Current) with 1492-AIFM8-F-5

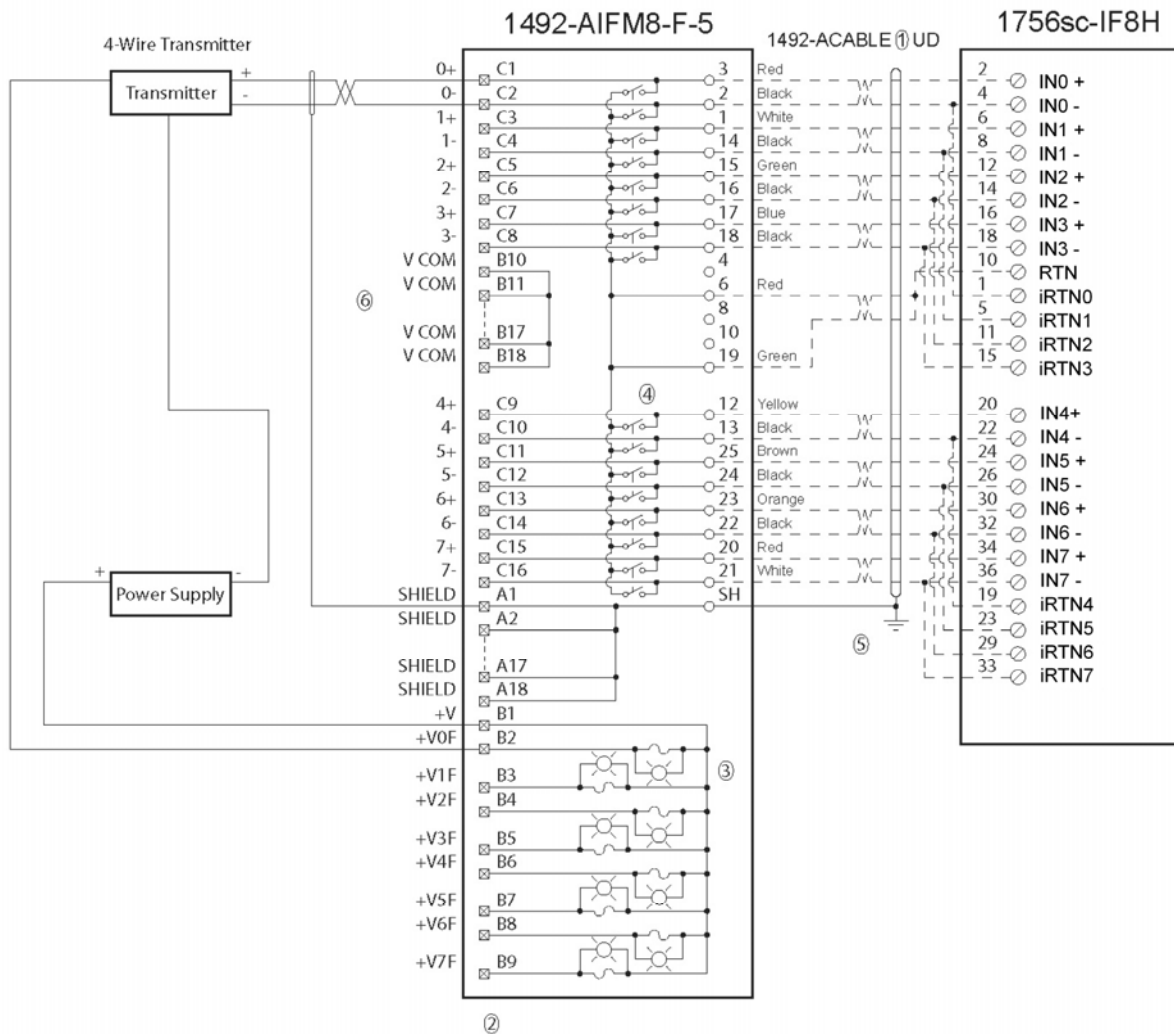

① Cables are available in 0.5m, 1.0m, 2.5m, and 5.0m standard lengths (005=0.5m, 010=1.0m, 025=2.5m, 050=5.0m). Custom length cables are also available.

② Terminals starting with A are the lower row of terminals, B terminals are the middle row, C terminals are the upper row.

③ LED provides blown fuse indication. When the fuse is blown the leakage current through the LED is 2mA nominal. One analog power source must be used with this module combination as the fuses are commoned on the AIFM.

④ Function of DIP switch is required by some PLC Analog Modules to short out unused analog channels to common when closed. Factory Position: Open. (refer to your PLC manual for details.)

⑤ Follow your PLC Analog User Manual for proper shield grounding instructions.

⑥ Terminals B10 through B18 can be used for field wire convenience connections. NOTE: they are connected together (commoned) on the AIFM.

1756sc-IF8H (8 Differential Voltage) with 1492-AIFM8-F-5

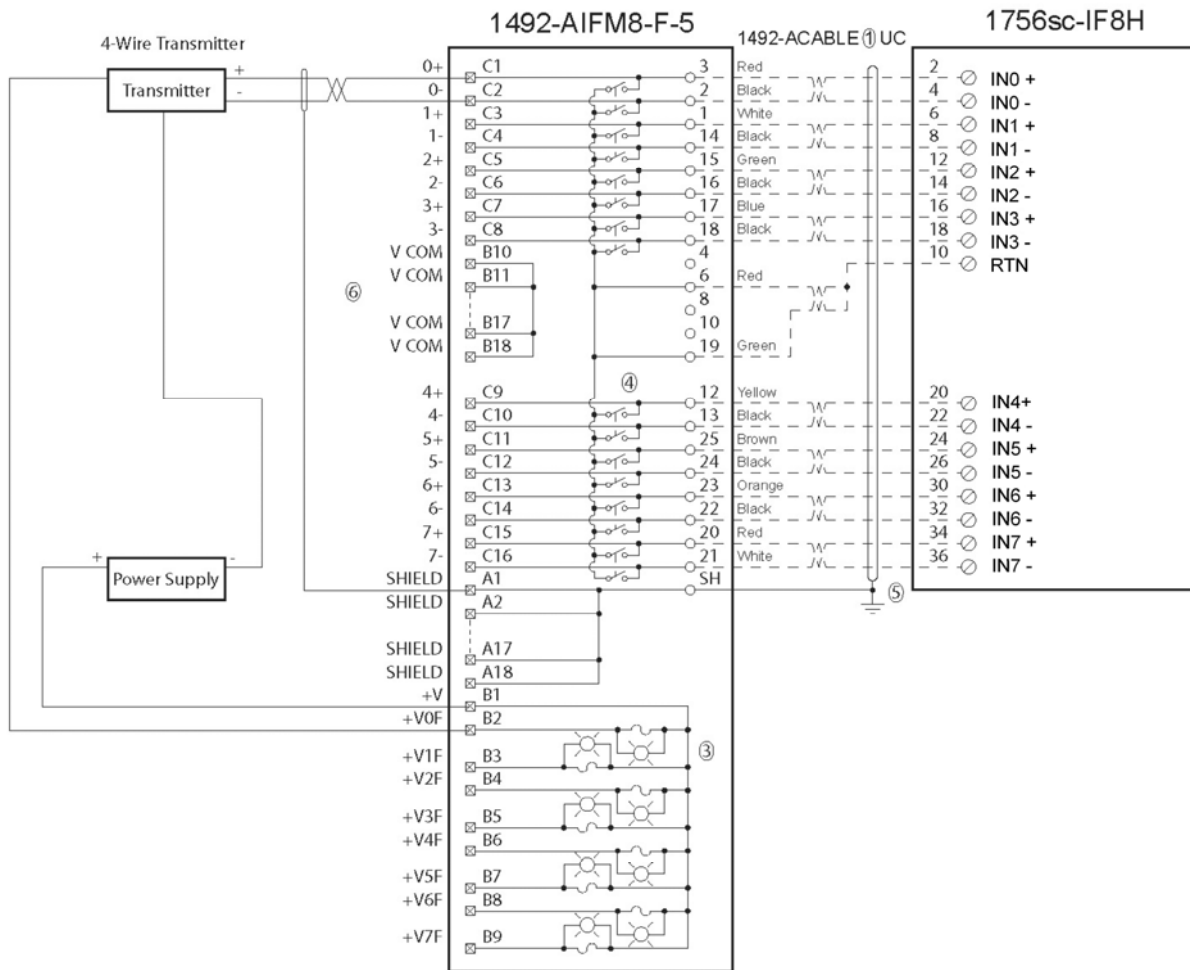

① Cables are available in 0.5m, 1.0m, 2.5m, and 5.0m standard lengths (005=0.5m, 010=1.0m, 025=2.5m, 050=5.0m). Custom length cables are also available.

② Terminals starting with A are the lower row of terminals, B terminals are the middle row, C terminals are the upper row.

③ LED provides blown fuse indication. When the fuse is blown the leakage current through the LED is 2mA nominal. One analog power source must be used with this module combination as the fuses are commoned on the AIFM.

④ Function of DIP switch is required by some PLC Analog Modules to short out unused analog channels to common when closed. Factory Position: Open. (refer to your PLC manual for details.)

⑤ Follow your PLC Analog User Manual for proper shield grounding instructions.

⑥ Terminals B10 through B18 can be used for field wire convenience connections. NOTE: they are connected together (commoned) on the AIFM.

1756sc-IF8H (8 Differential Current) with 1492-AIFM16-F-3

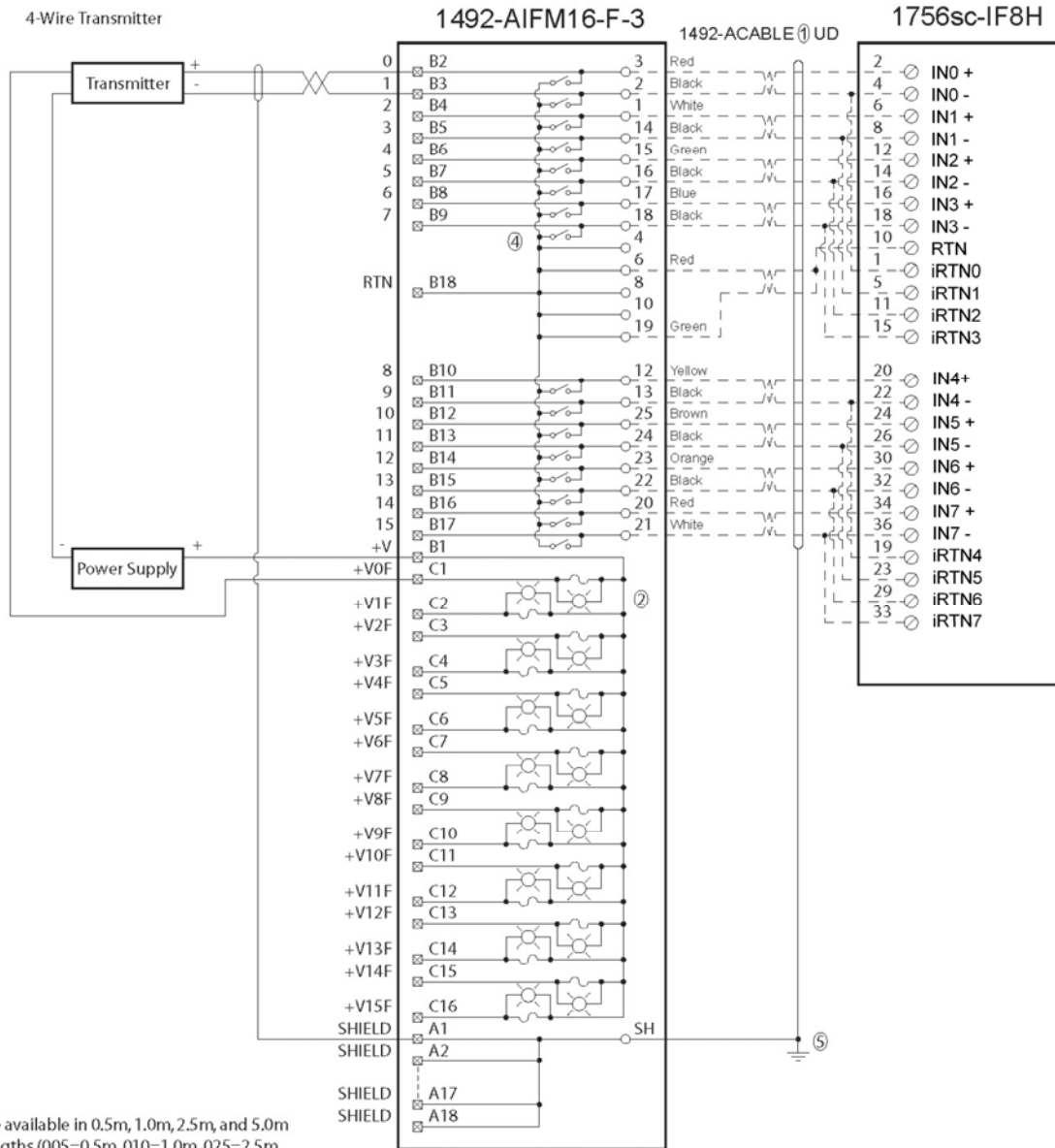

① Cables are available in 0.5m, 1.0m, 2.5m, and 5.0m standard lengths (005=0.5m, 010=1.0m, 025=2.5m, 050=5.0m). Custom length cables are also available.

② LED provides blown fuse indication. When the fuse is blown the leakage current through the LED is 2mA nominal. One analog power source must be used with this module combination as the fuses are commoned on the AIFM.

③ Terminals starting with A are the lower row of terminals, B terminals are the middle row, C terminals are the upper row.

④ Function of DIP switch required by some PLC analog modules to short unused channels to common when closed. Factory Position: Open. (Refer to your PLC manual for details).

⑤ Follow your PLC Analog User Manual for proper shield grounding instructions.

1756sc-IF8H (8 Differential Voltage) with 1492-AIFM16-F-3

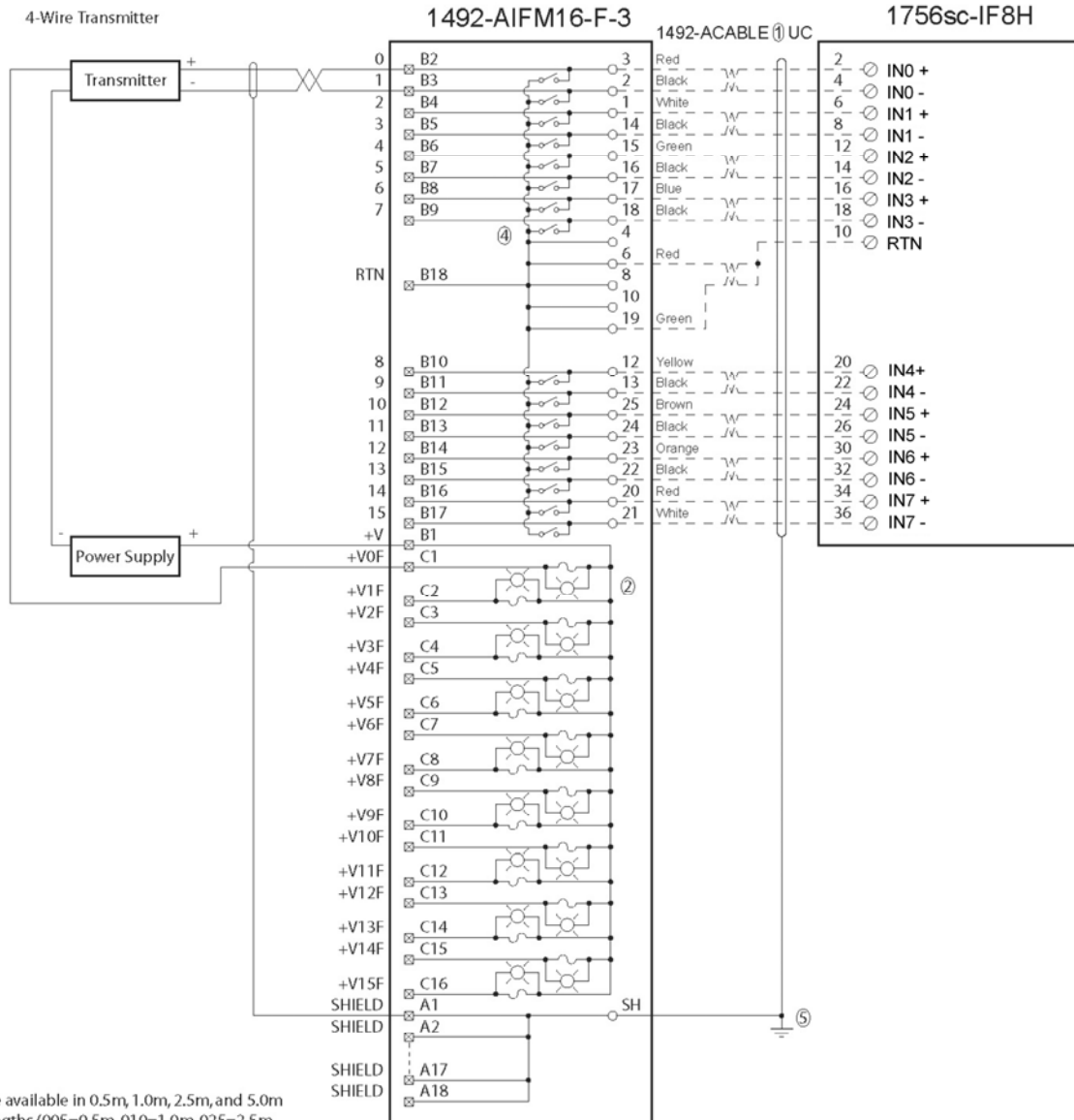

① Cables are available in 0.5m, 1.0m, 2.5m, and 5.0m standard lengths (005=0.5m, 010=1.0m, 025=2.5m, 050=5.0m). Custom length cables are also available.

② LED provides blown fuse indication. When the fuse is blown the leakage current through the LED is 2mA nominal. One analog power source must be used with this module combination as the fuses are commoned on the AIFM.

③ Terminals starting with A are the lower row of terminals, B terminals are the middle row, C terminals are the upper row.

④ Function of DIP switch required by some PLC analog modules to short unused channels to common when closed. Factory Position: Open. (Refer to your PLC manual for details).

⑤ Follow your PLC Analog User Manual for proper shield grounding instructions.

1756sc-IF8H (Differential Current) with 1492-AIFM16-F-5

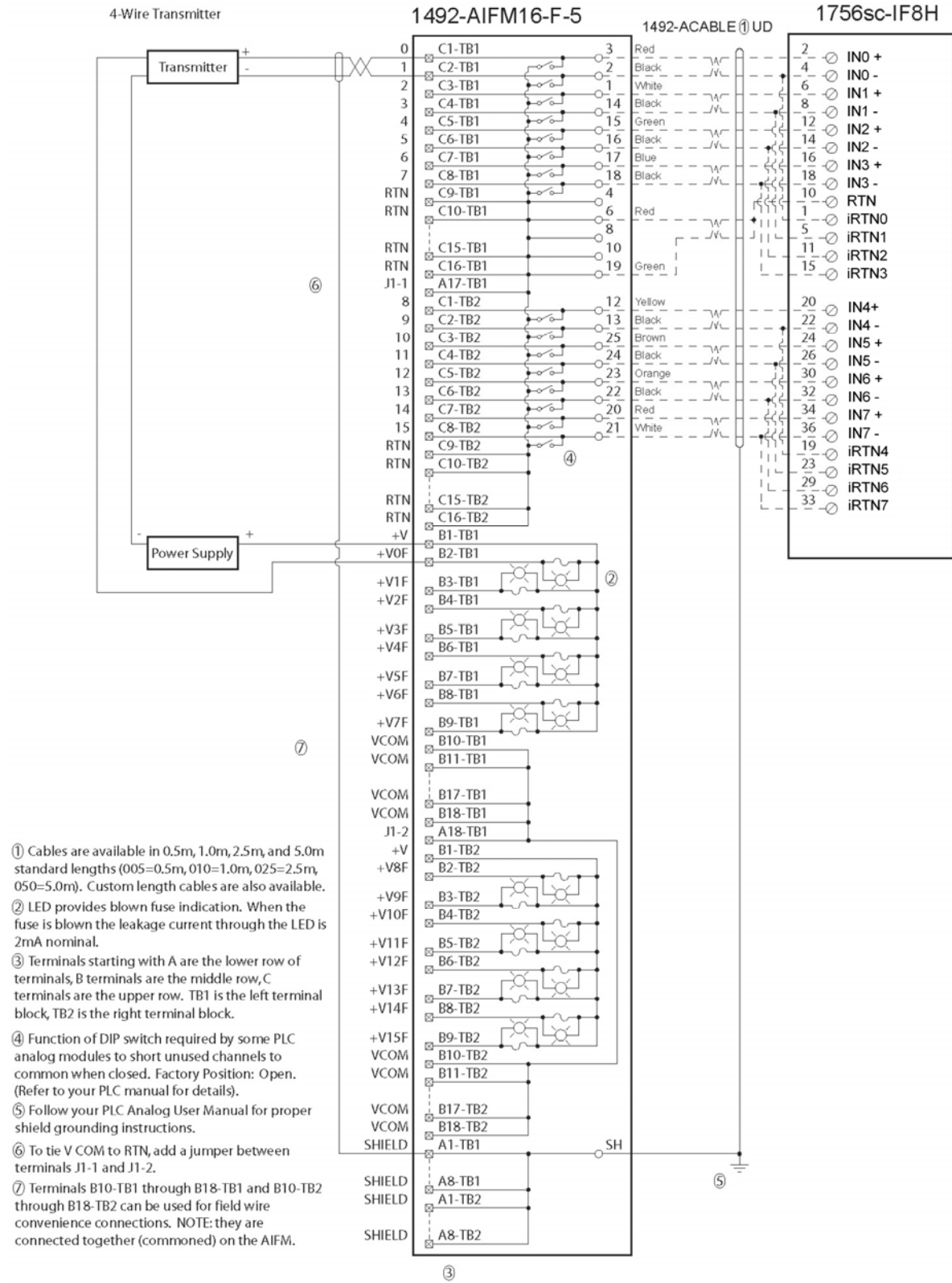

1756sc-IF8H (8 Differential Voltage) with 1492-AIFM16-F-5

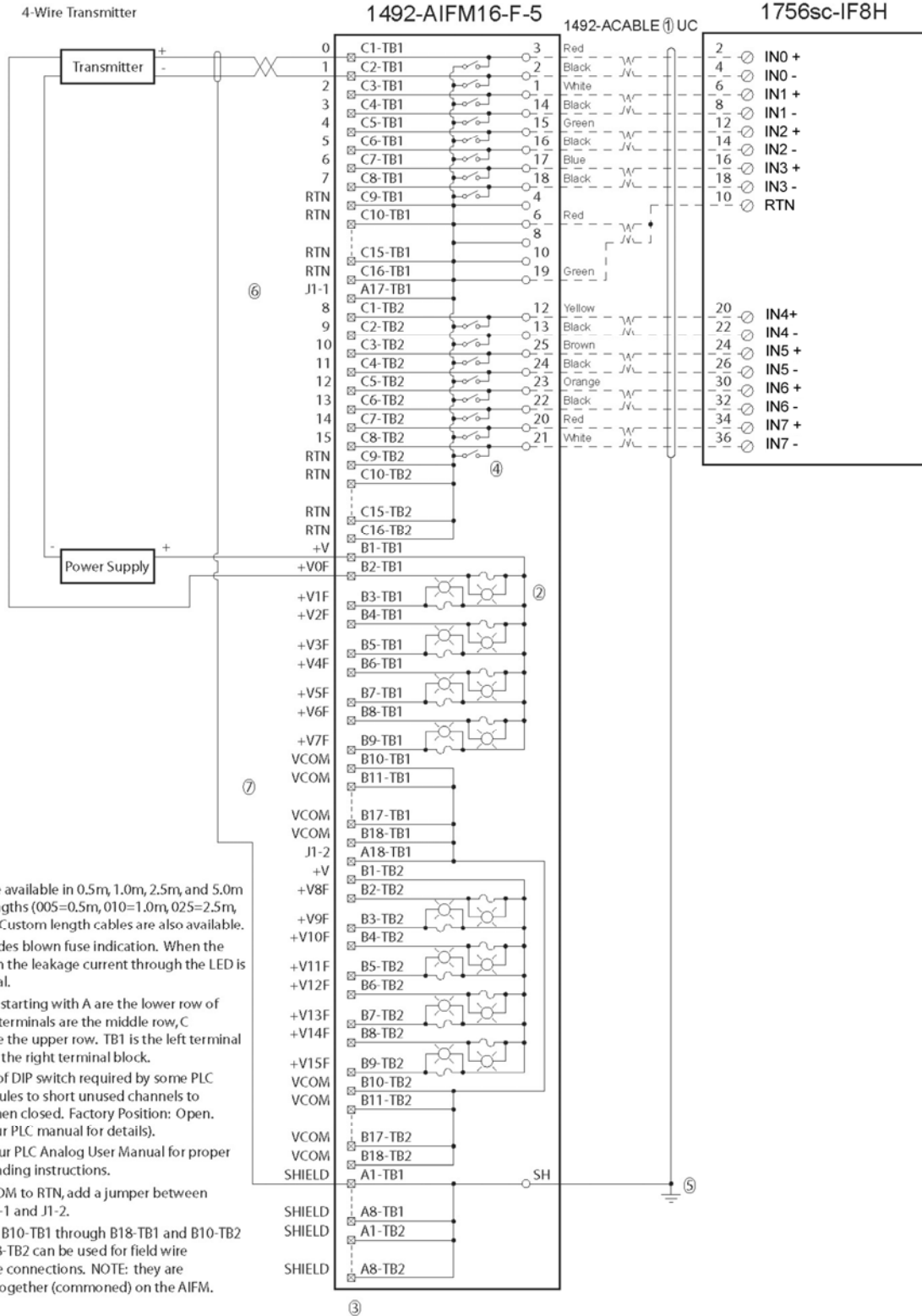

1756sc-OF8H (Current) with 1492-AIFM8-3

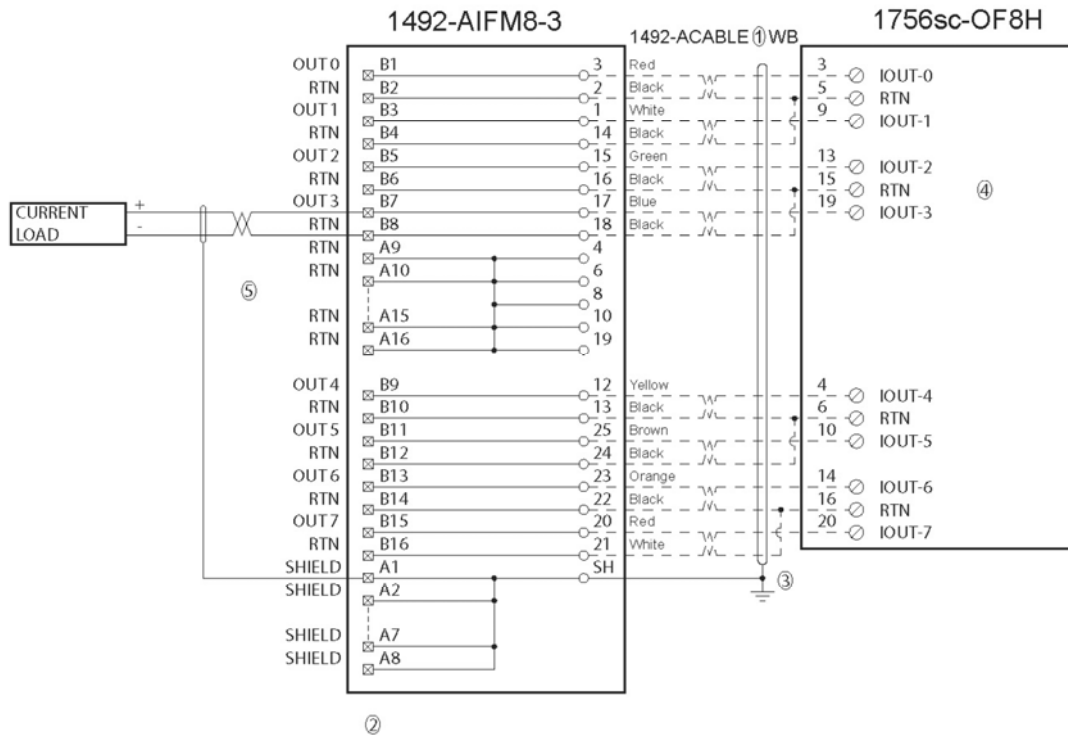

① Cables are available in 0.5m, 1.0m, 2.5m, and 5.0m standard lengths (005=0.5m, 010=1.0m, 025=2.5m, 050=5.0m). Custom length cables are also available.

② Terminals starting with A are the lower row of terminals, B terminals are the upper row.

③ Follow your PLC Analog User Manual for proper shield grounding instructions.

④ RTN terminals are internally connected on the 1756-OF8.

⑤ Terminals A9 through A16 can be used for field wire convenience terminals. NOTE: this is only true for this module combination, since the 1492-ACABLExxxWB does not connect to these terminals.

1756sc-OF8H (Voltage) with 1492-AIFM8-3

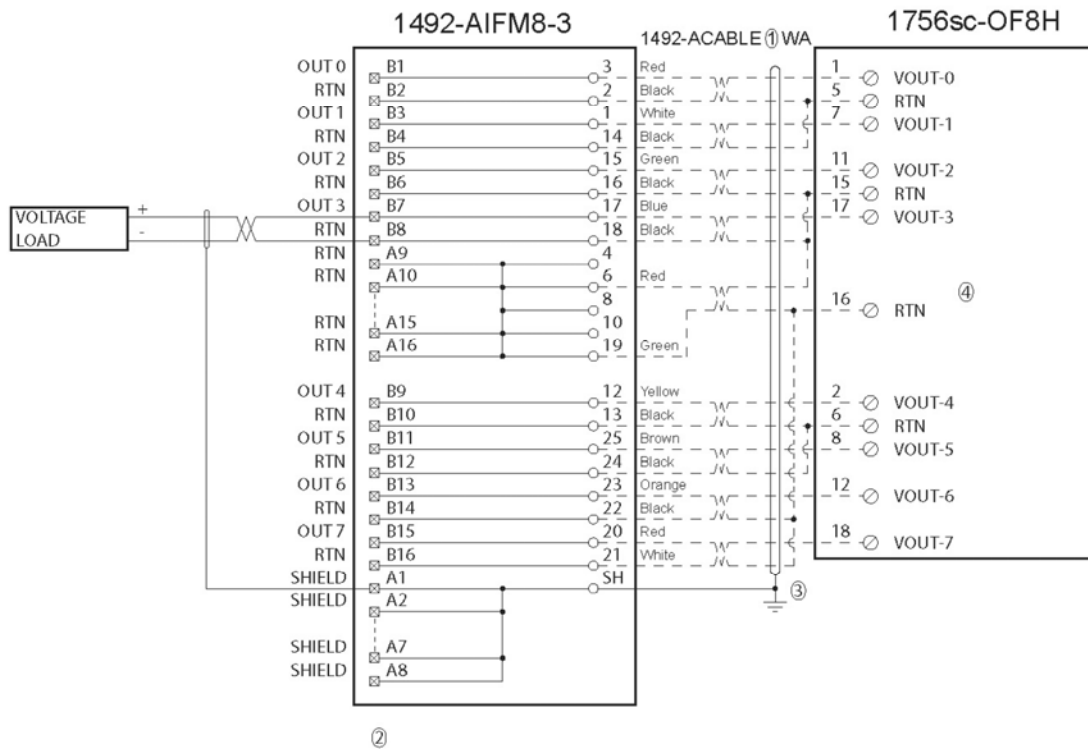

① Cables are available in 0.5m, 1.0m, 2.5m, and 5.0m standard lengths (005=0.5m, 010=1.0m, 025=2.5m, 050=5.0m). Custom length cables are also available.

② Terminals starting with A are the lower row of terminals, B terminals are the upper row.

③ Follow your PLC Analog User Manual for proper shield grounding instructions.

④ RTN terminals are internally connected on the 1756-OF8.